

Perfect Energy Saving Drive LS Medium Voltage VFD

3kV 200kVA ~ 3,700kVA
4kV 250kVA ~ 4,700kVA
6kV 400kVA ~ 7,500kVA
10kV 600kVA ~ 11,100kVA

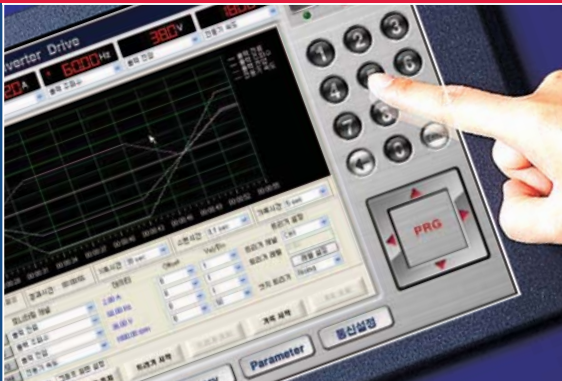

Drive Solution



- The most efficiency energy management for great energy saving.
- User friendly convenience monitoring system
- Optimum solution for variety industry fields.

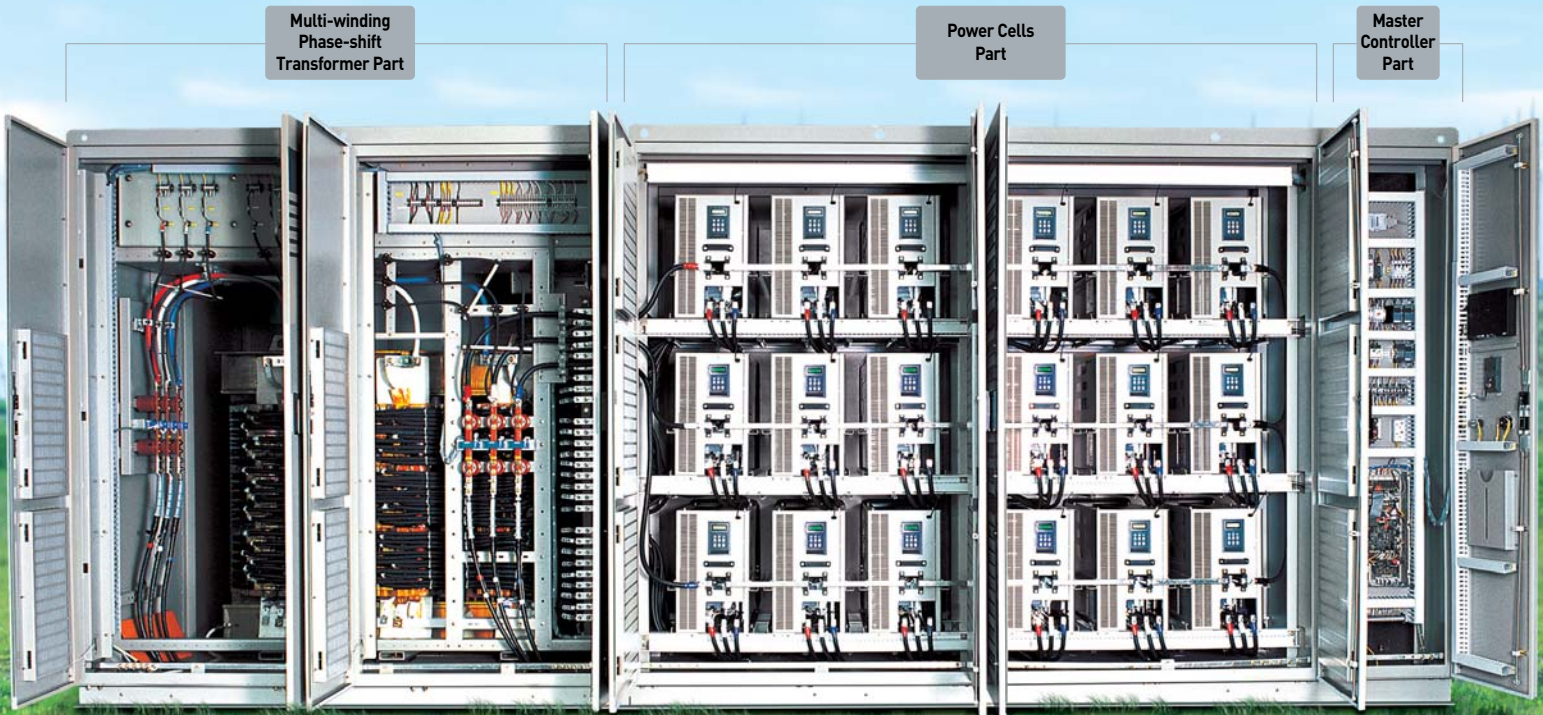

»»» Sensorless Vector Control

- MV VFD adopts powerful Sensorless vector control algorithm on the basis of LV VFD's technology, and it improves not only the torque control characteristics, but the speed control ability in uncertain condition caused by the load variation as well.
- MV VFD generates strong torque at a low speed range as shown below.

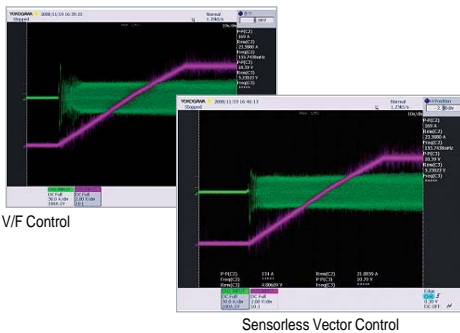

»»» Flying Start

- In case of more than 2 fans operated in one system or heavy fan spinning by inertia, MV VFD detects motor's speed and is able to control motor effectively.

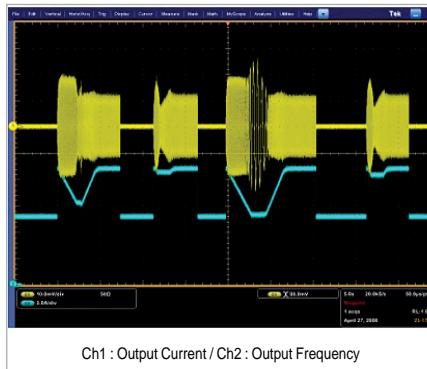

»»» Auto tuning

- In the application which requires a high torque at low speed, the electrical parameters of motor should be properly set for an optimal operation.
- The Auto tuning function automatically measures the motor parameters needed for control selected in control mode such as stator resistance, rotor resistance, leakage inductance and no-load current.

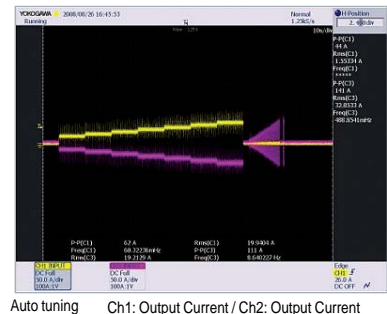

Configuration of Medium Voltage VFD (6600V)

Multi-winding Transformer

Cell input voltage can be connected each terminal and 36 pulse/18 winding of dry type phase-shift transformer has equipped. Also it has constructed 5% tap for input voltage change.

Power Cells

6 cell connected in series per VFD output phase. It occurs 25 level, 3 phase output voltage. Each cell uses PWM switching with distributed control process. Cell maintenance is user friendly as self cell protection and built-in bypass function.

Master Controller

There is a Master Controller for managing PWM output voltage. It uses CAN communication and controls VFD with 18 each unit cell and optical communication. It also has user friendly MV System View for system maintaining and monitoring

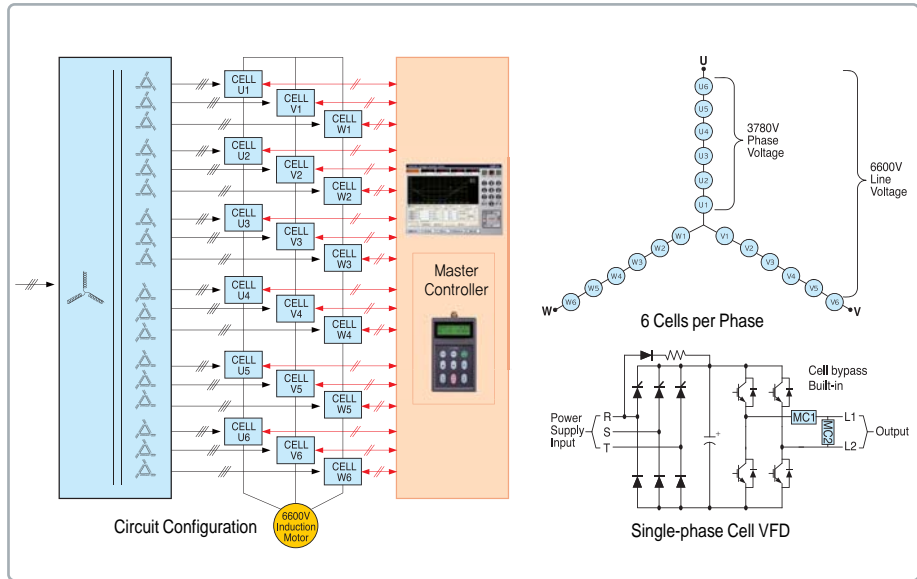

Energy Saving

Compared to the airflow control by using dampers, the VFD saves more energy.

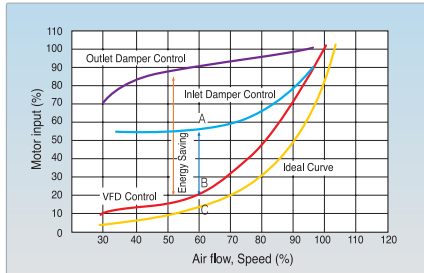

Conditions

- (1) Applicable Motor: 3300V, 600kW, 6P (with 95% motor Efficiency)
- (2) 60% airflow operation (with 90% motor efficiency at 100% airflow)

1. Power at inlet damper control

$$600 \times 0.9 \times 0.55 \times \frac{1}{0.95 \text{ Motor efficiency}} = 312.6kW \dots (1)$$

2. Power at VFD energy saving control

Motor output (point C)

$$600 \times 0.9 \times (0.6)^3 = 116.6kW \dots (1)$$

Motor input power

$$116.6 \times \frac{1}{0.95 \text{ Motor efficiency}} = 122.7kW$$

VFD input power (point b)

$$122.7 \times \frac{1}{0.95 \text{ VFD efficiency}} = 129.2kW \dots (2)$$

3. Energy Saving

Annual energy saving by VFD (1) - (2)

$$(312.6 - 129.2)kW \times 8,000h = 1,467,200kWh$$

* Assume that annual motor operating time is 8,000 hours

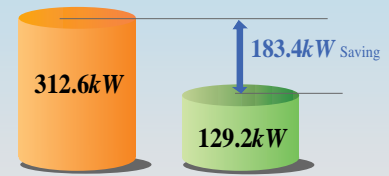

Annual electric charge can be saved

$$1,467,200 \times 9 = 13,204,800 \text{ cent} = 13,204.8 \text{ dollar}$$

* Assume 9 cent per kWh

Compact Size

- MV VFD has designed an optimum inner panel through heat analysis; it promotes to get the most out of space.

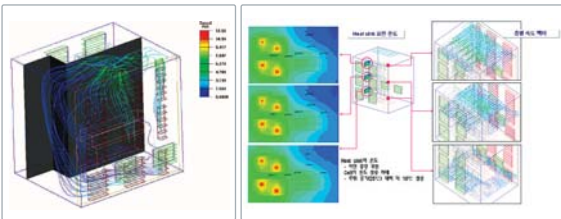

Energy Saving & High Efficiency

- MV VFD realizes high efficiency and high power factor more than 95% without any compensation tools.
- MV VFD realizes perfect energy saving VFD system without input/output filter.

Redundant Cell Power Factor Control

- MV VFD has no extra charge for low power factor.
- MV VFD's voltage regulation is advanced.
- MV VFD keeps High power factor with standard induction motor in all of the speed range. (More than 95%)

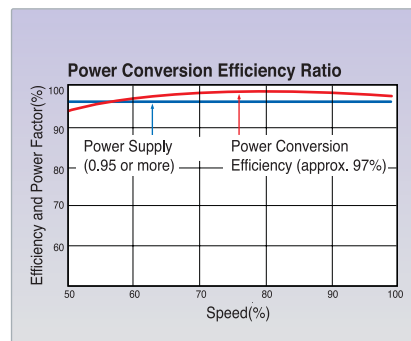

Built-in Cell Bypass

- In case of cell failure during operation, the fault cell is bypassed and the neutral point is shifted 83% of the rated voltage can be output after the failure of one cell.
- This function can be operated by automation and manual setting.
- MV VFD's drag torque is constantly maintained when cell is bypassed.

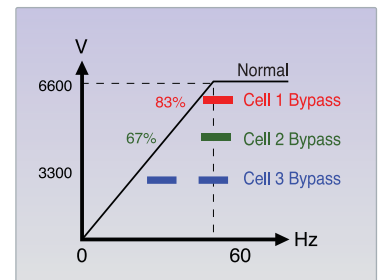

>>> System Configuration

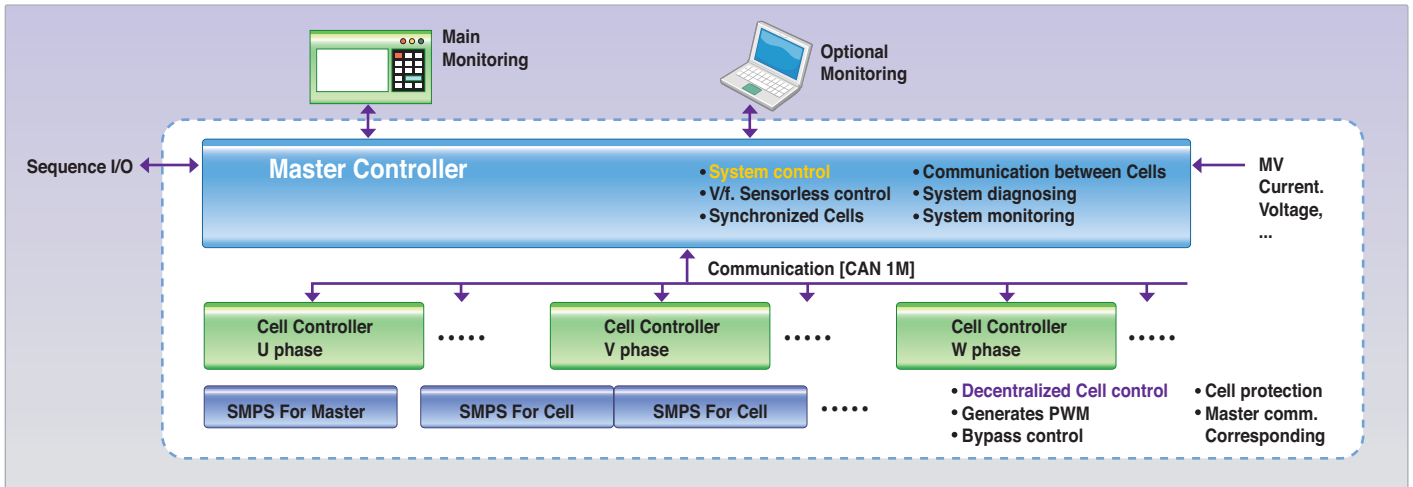

>>> MV System View (Option)

The image shows the **Medium Voltage Inverter Drive** control interface. It features a central graph displaying drive status and data. To the right of the graph is a keypad with buttons for **Forward/Backward, Stop/Reset Commands** and LEDs for running direction. Below the keypad is a touch screen with a **PRG** button. The interface includes a **Monitoring stop trigger function** and the ability to **continuously save the monitoring data at specified intervals**. Touching one of the buttons will display the window for each of the selected categories.

- Displays the status of drive operation
- Displays max. of 4 common field data in each segment
- Buttons for Forward/Backward, Stop/Reset Commands
- These LEDs Display running direction of the connected drive
- This is a touch screen based operation system
- User can set the data by using either a Keypad or a Direction pad
- Displays max. of 4 common field data in graph form
- Has a monitoring stop trigger function in case of certain situation
- Can continuously save the monitoring data at specified intervals
- Touching one of these buttons will display the window for each of selected category.

>>> FAN speed control by inverter internal heat value

Automatic control for cooling FAN compatible with inverter internal temperature

- Reduced FAN noise with optimized control
- Reduced power consumption of FAN
- Extended durability of FAN

Speed control compatible with the temperature variation

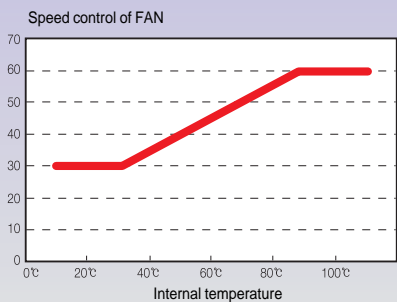

>>> New algorithm for an anti-current hunt

- When the motor operates, mechanic resonant or resonant point of each component's organic union makes current hunt. It occurs over current trip or damaged motor shaft.
- New algorithm, the advanced technology compared with the currently jump function, resolves the current hunt generated by the resonance of the frequency in the specific site and it drives with stable in all frequencies of the operating sector

Without New Algorithm

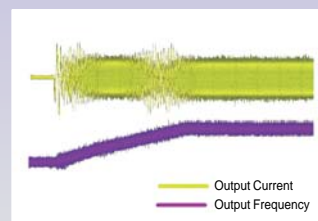

With New Algorithm

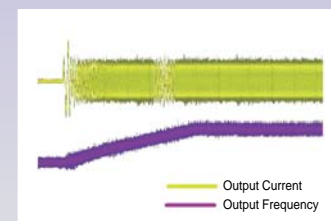

Standard Specifications

3kV Class	Model Number [60Hz]	LSMV-033S200	LSMV-033S300	LSMV-033S400	LSMV-033S500	LSMV-033S600	LSMV-033S750	LSMV-033S10H	LSMV-033S12H	LSMV-033S15H	LSMV-033S20H	LSMV-033S25H	LSMV-033S30H	LSMV-033S37H
	Model Number [50Hz]	LSMV-030F200	LSMV-030F300	LSMV-030F400	LSMV-030F500	LSMV-030F600	LSMV-030F750	LSMV-030F10H	LSMV-030F12H	LSMV-030F15H	LSMV-030F20H	LSMV-030F25H	LSMV-030F30H	LSMV-030F37H
	Output Capacity [kVA]	200	300	400	500	600	750	1000	1200	1500	2000	2500	3000	3700
	Cell Rated Current [A]	35	53	70	88	105	131	175	218	260	350	438	525	657
	Max. Applicable Motor Capacity [kW]	160	250	330	410	500	620	850	1000	1250	1700	2080	2500	3150
4kV Class	Model Number	LSMV-041F250	LSMV-041F380	LSMV-041F500	LSMV-041F630	LSMV-041F750	LSMV-041F950	LSMV-041F12H	LSMV-041F15H	LSMV-041F19H	LSMV-041F25H	LSMV-041F31H	LSMV-041F37H	LSMV-041F47H
	Output Capacity [kVA]	250	380	500	630	750	950	1200	1500	1900	2500	3100	3700	4700
	Cell Rated Current [A]	35	53	70	88	105	131	175	218	260	350	438	525	657
	Max. Applicable Motor Capacity [kW]	200	310	410	530	620	790	1000	1250	1580	2080	2650	3150	4000
6kV Class	Model Number [60Hz]	LSMV-066S400	LSMV-066S600	LSMV-066S800	LSMV-066S10H	LSMV-066S12H	LSMV-066S15H	LSMV-066S20H	LSMV-066S25H	LSMV-066S30H	LSMV-066S40H	LSMV-066S50H	LSMV-066S60H	LSMV-066S75H
	Model Number [50Hz]	LSMV-060F400	LSMV-060F600	LSMV-060F800	LSMV-060F10H	LSMV-060F12H	LSMV-060F15H	LSMV-060F20H	LSMV-060F25H	LSMV-060F30H	LSMV-060F40H	LSMV-060F50H	LSMV-060F60H	LSMV-060F75H
	Output Capacity [kVA]	400	600	800	1000	1200	1500	2000	2500	3000	4000	5000	6000	7500
	Cell Rated Current [A]	35	53	70	88	105	131	175	218	260	350	438	525	657
	Max. Applicable Motor Capacity [kW]	330	500	660	850	1000	1250	1700	2080	2500	3400	4100	5000	6200
10kV Class	Model Number	LSMV-100F600	LSMV-100F900	LSMV-100F12H	LSMV-100F15H	LSMV-100F18H	LSMV-100F22H	LSMV-100F30H	LSMV-100F37H	LSMV-100F45H	LSMV-100F60H	LSMV-100F75H	LSMV-100F90H	LSMV-100F11M
	Output Capacity [kVA]	600	900	1200	1500	1800	2200	3000	3700	4500	6000	7500	9000	11000
	Cell Rated Current [A]	35	53	70	88	105	132	175	218	260	350	438	525	657
	Max. Applicable Motor Capacity [kW]	500	700	1000	1250	1500	1800	2500	3150	3800	5000	6200	7200	9300
Power Factor	Around 95% (20%~100% of Load)													
Efficiency	Around 97% (at Rated Load Condition)													
Input THD Current	Less 3%(30% ~100% of Load)													
Input	Main Current	3 Phase 3kV/3.3kV/4.16kV/6kV/6.6kV/10kV ±10%, 50/60Hz												
	Control Current	3 Phase 220V/380V/440V ±10%, 50/60Hz ±5%												
Output	Rated Voltage	3 Phase 3kV/3.3kV/4.16kV/6kV/6.6kV/10kV Max. 25 level												
	Output Frequency	0~120 Hz												
Control Specification	Control Method	V/F, Sensorless Vector												
	Frequency Accuracy	±0.1%												
	Frequency Setting Resolution	0.01Hz												
	Accel/Decel Time	0.1~6000 sec												
	Overload Capacity	120% per 1 min.												
Operation	Operation Functions	Flying Start, Cell Bypass												
	LCD Keypad	RS232, Modbus-RTU, Key Input												
	MV System View ^{*Note1}	Option : Touch Screen Type LCD 12.1 inch wide viewing angle, 144 color TFT-LCD Resolution: 1024 X 768, Response time: 40m sec response												
Input/Output Signal	Digital	Input: 15ch, Output: 9ch												
	Analog	Input: 3ch (DC 0~10V or 0~20mA)												
Protective (Trip & Alarm)	Over Current, Over Voltage, Low voltage, Ground Fault, Drive Overheat, Motor Overheat, Fan Trip, Overload, Comm. Error, Cell Trip													
Communication	Built-in RS485(or Modbus-RTU) Option : DeviceNet, Profibus-DP, EtherNet-IP, CAN, CANopen, Lonwork													
Structure	Protection Degree	IP21												
	Cell Bypass	Built-in Standard (Auto/Manual Bypass)												
	Cooling Method	Air-Cooling												
Environment	Ambient Temperature	0~40°C												
	Ambient Humidity	Less than 85% RH Max. (Non-Condensing)												
	Altitude	Below 1,000m (3,281ft)												
	Installation	Indoor use only												
Input Transformer	Class H, Air-Cooling Type, N/+5%/10% or -5%/N/+5%													

*Note1) : Option

Model Number

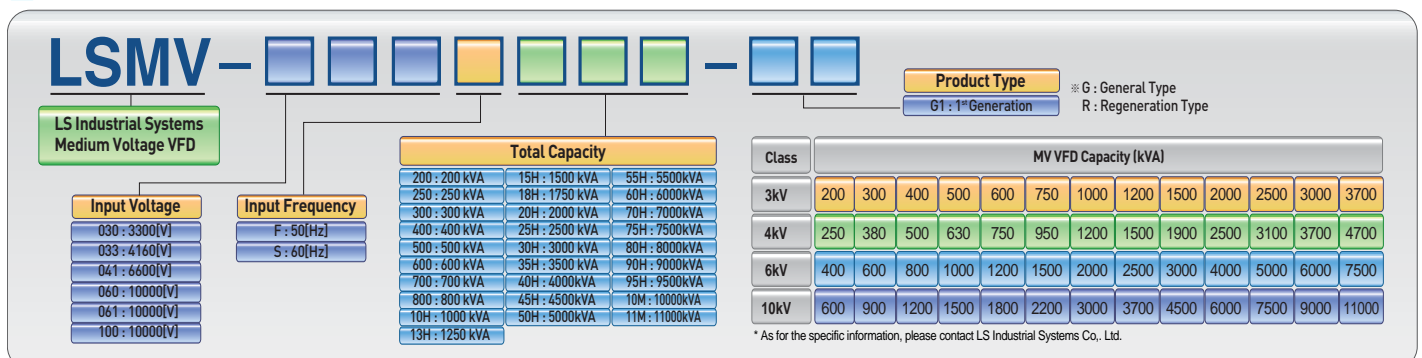

Power Terminal Configuration

Symbol	Description
R	AC Line Voltage Input 3.3kV/4.16kV/6.6kV 60Hz
S	
T	
U	3 Phase Power Output Terminals to Motor
V	
W	
EA	Earth Ground: Smaller than 10 ohm
RC	Control Power 3 Phase, 220V/380V/440V, 50Hz or 60Hz (Voltage: ±10%, Frequency: ±5%)
SC	
TC	

Control Terminal Configuration

Type	Symbol	Name	Description
Input Signal	A01	Freq Reference	User Selection (DC 0~10V or 4~20mA)
	A02		
	A03		
Output Signal	A04	Output Freq	User Selection (DC 0~10V or 4~20mA) Spare 2 Signal
	A05	Output Current	
	A07		
	A08		
Input Signal	1	Speed-L	Speed-L : default
	2	Speed-M	Speed-M : default
	3	Speed-H	Speed-H : default
	4	EXT TRIP 1	Trip : default
	5	JOG	Jog Frequency Reference : default
	6	FX	Fwd Run : default
	7	RX	Rev Run : default
	8	NONE	User Select
	9	NONE	User Select
	10	TRANS.OHT	Transformer Overheat : default
	11	FAN.TRIP	Fan Trip : default
	12	High Voltage.ON	
	13	Run.Enable	Run Signal : default
	14	BX	Drive Disable : default
Output Signal	AXA1	READY	Ready Mode : default
	AXA2	FAN.RUN	Fan Run : default
	AXA3	NORMAL	Normal Mode : default
	AXA4	RUN Enable	Run Mode : default
	AXA5	WARNING	Warning : default
	AXA6	NONE	User Select
	AXA7	NONE	User Select
	AXA8	NONE	User Select
	30ACB	TRIP	Trip Information

Select from : FX / RX / JOG / BX / Speed-L / Speed-M / Speed-H / Speed-X / XCEL-L / XCEL-M / XCEL-H / UP / Down 3-wire / Analog Hold / Ana. Change / XCEL stop / (Loc/Rem) / Door Open / Trans. OHW / Trans. OHT / Motor OHT / Fan Trip / Ext Trip1 / Ext Trip2 / High_Voltage / Run_Enable / None

None / FDT-1 / FDT-2 / FDT-3 / FDT-4 / FDT-5 / OL / IOL / Stall / OV / LV / OH / Lost Command / Run / Stop / Steady / Speed Search / Ready / Warning / Fan run / Normal / OC Trip / Cell Bypass

Systems Protective Function

Protection/LCD Display	Description
Current Limit Protection/ Inv. OLT	The drive disables its output if the output current exceeds the continuous current rating for a prolonged period of time.
BX Protection (Instant Cut Off) / BX	Used as an drive disable. The drive instantly disables its output when the BX terminal is turned ON. The drive returns to normal operation when the BX terminal is turned OFF.
External Trip / Ext.Trip 1 / Ext.Trip 2	When External Trip is enabled, the drive will disables its output if an External Trip Signal(normally open contact), is detected. The external trip can be used to block the output to protect a motor if an external overload relay is used or to block operation if an motor or brake resistor over-temperature condition is indicated.
CAN Comm. Error/ CAN Error	This Error occurs when the communication between the Master Controller and the Power Cells does not go smoothly.
Fan Error/ FAN Error	The drive disables its output when the Fan malfunction is detected.
Over Current Protection/ Output OCT	The drive disables its output when the current exceeds its current limit.
Output Phase Open / Out Phase Open	The drive disables its output when one or more output phase (U,V,W), is open. The Drive monitors output current to detect an output phase loss.
Input Phase Open/ In Phase Open	The drive disables its output when one or more input phase (R,S,T), is open.
Ground Fault Protection / Ground Fault	The drive disables its output when a ground fault is detected. The ground fault trip will occur when the ground current exceeds the internal set value. An Over Current trip may occur if the cause of ground current is due to a low resistance condition.
Electronic Thermal Overload / E-Thermal	The drive internal Motor Electronic Thermal Overload operates similar to a motor thermal switch to protect the motor from overheating damage. If the drive is being used in an application where more than one motor is connected to the drive, each motor must have its own thermal protective device.
Motor Overheat / Motor OverHeat	The drive disables its output if the motor reaches its over-temperature threshold.
Power Cell Fault / Cell Fault	The drive disables its output when a malfunction signal from the power cell is detected.
Low Voltage Trip / Input LVT	The drive disables its output if the input voltage falls below its low voltage detection level.
Over Voltage Trip / Input OVT	The drive disables its output if the input voltage exceeds the rated value.
Transformer Overheat / Trans OverHeat	The drive disables its output if the transformer reaches its over-temperature threshold.
Door Open / Door Open	The drive disables its output when the panel door open signal is detected.
DC-Link Over Voltage / DC-Link OVT	The drive disables its output if the DC-Link voltage of its cell exceeds the rated value.
Power Cell Overheat / CELL OverHeat	The drive disables its output if the heatsink of its cell reaches its over-temperature threshold due to ambient temperature rise, cooling fan malfunction, clogged filter, etc.
Over Load Trip / Over Load	The drive turns off its output if the output current of the drive is at greater than 120% of the drive rated current.

Cell Protective Function

Protection	LCD Display	Description
Over Current 1	Over Current 1	The drive disables its output when the output current from the power cell exceeds its current limit.
Over Voltage	Over Voltage	The drive disables its output if the DC bus voltage exceeds the rated value. Possible cause: 1. DC Voltage may increase due to motor deceleration time too short for the load inertia. 2. High AC input voltage or surge.
Over Current 2	Over Current 2	The drive disables its output if an IGBT short is detected, or if an output short occurs.
Over Heat	Over Heat	The drive disables its output if the heatsink of the cell reaches its over-temperature threshold and it is detected by the Master Controller.
Fuse Open	Fuse Open	The drive disables its output when the fuse inside of power cell is damaged due to over current.
Low Voltage	Low Voltage	The drive disables its output if the DC Link voltage falls below its low voltage detection level.
CAN Comm. Error	CAN_RX_Error	The drive disables its output when the problem is detected on the CAN communication.
NTC Open	NTC Open	The drive disables its output when the Cell thermal is open. Possible cause: 1. Wiring between drive and Cell NTC/PTC is faulty. 2. Failed NTC/PTC.

Form for quotation

1 Name of Application

2 Type of Load Pump Fan Blower Compressor Others

3 Torque Characteristics Variable Torque Proportional Torque
 Constant Torque Constant Output $J(GD^2/4)$ kg·m²

4 Operation Conditions Motor Current _____ A , Annual Operation Time _____ hours

5 Motor Specifications Squirrel-Cage Induction motor Wound-Rotor Type Motor
 Existing New
Output _____ kW , Voltage _____ V , Frequency _____ Hz , Pole Number _____ P
Speed _____ min , Rated Current _____ A , Efficiency _____ % , Power Factor _____ %

6 Speed Control Range Minimum _____ /min to Maximum _____ /min or Minimum _____ /Hz to Maximum _____ /Hz

7 Acceleration/Deceleration Time Setting Acceleration Time _____ Second(s) / _____ min
Deceleration Time _____ Second(s) / _____ min

8 Overload Capacity _____ % / _____ Second(s)

9 By-Pass Operation Circuit Required < Automatic Manual >

10 Power Supply Specifications Main Circuit Voltage _____ V , _____ Hz
Control Circuit Voltage 220V 3P 380V 3P 440V 3P Others _____ V 3P

11 Ambient Conditions Indoors
 Ambient Temperature _____ °C , Humidity _____ % or less
 Air-Conditioning Facility (Provided Not Provided)
 Install Space (Width _____ mm Height _____ mm Depth _____ mm)
 Cable Entry (Bottom Top)

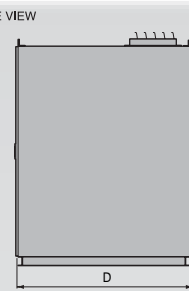
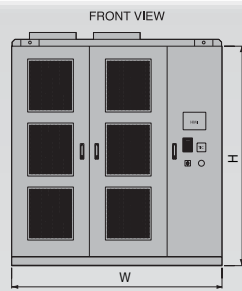
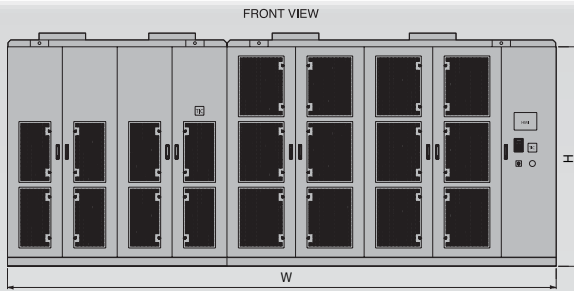

Unit : mm

Voltage Class (V)	Capacity (KVA)	Dimensions		
		W	D	H
3,000 / 3,300	200	1,600	1,800	2,350
	300	1,600	1,800	2,350
	400	1,600	1,800	2,350
	500	1,600	1,800	2,350
	600	3,600	1,800	2,350
	750	3,600	1,800	2,350
	1000	3,600	1,800	2,350
	1200	3,600	1,800	2,350
	1500	3,600	1,800	2,350
	2000	4,000	1,800	2,350
	2500	4,000	1,800	2,350
	3000	5,000	1,800	2,350
	3700	5,000	1,800	2,350
4,160	250	2,000	1,800	2,350
	380	2,000	1,800	2,350
	500	2,000	1,800	2,350
	630	2,000	1,800	2,350
	750	4,200	1,800	2,350
	950	4,200	1,800	2,350
	1200	4,200	1,800	2,350
	1500	4,200	1,800	2,350
	1900	4,200	1,800	2,350
	2500	5,000	1,800	2,350
	3100	5,000	1,800	2,350
	3700	6,000	1,800	2,350
	4700	6,000	1,800	2,350

Unit : mm

Voltage Class (V)	Capacity (KVA)	Dimensions		
		W	D	H
6,000 / 6,600	400	2,400	1,800	2,350
	600	2,400	1,800	2,350
	800	2,400	1,800	2,350
	1000	2,400	1,800	2,350
	1200	4,800	1,800	2,350
	1500	4,800	1,800	2,350
	2000	4,800	1,800	2,350
	2500	4,800	1,800	2,350
	3000	4,800	1,800	2,350
	4000	6,000	1,800	2,350
	5000	6,000	1,800	2,350
	6000	8,000	1,800	2,350
	7500	8,000	1,800	2,350
10,000	600	2,400	1,800	2,350
	900	2,400	1,800	2,350
	1200	2,400	1,800	2,350
	1500	2,400	1,800	2,350
	1800	6,000	1,800	2,350
	2200	6,000	1,800	2,350
	3000	6,000	1,800	2,350
	3700	6,000	1,800	2,350
	4500	6,000	1,800	2,350
	6000	7,500	1,800	2,350
	7500	7,500	1,800	2,350
	9000	10,000	1,800	2,350
	11000	10,000	1,800	2,350

©2009.03 LS Industrial Systems Co., Ltd. All Rights Reserved.

LS Industrial Systems Co., Ltd.

www.lsis.biz

HEAD OFFICE

LS Tower 1026-6, Hogue-dong, Dongan-gu,
Anyang-si, Gyeonggi-do 431-848, Korea

- Europe +82-2-2034-4376 / ywsohn@lsis.biz
- Middle East +82-2-2034-4901 / bonseongk@lsis.biz
- South West Asia +82-2-2034-4645 / sungkyup@lsis.biz
- South East Asia +82-2-2034-4707 / ohpark@lsis.biz
- CIS +82-2-2034-4913 / jinhkang@lsis.biz
- America +82-2-2034-4377 / younsupl@lsis.biz
- Africa +82-2-2034-4910 / khweikim@lsis.biz

Global Network

- **LS Industrial Systems (Middle East) FZE** >> Dubai, U.A.E.
Address: LOB 19 JAFZA VIEW TOWER Rm 205 Jebel Ali Freezone, P.O.BOX 114216, Dubai, U.A.E.
Tel: 971-4-886 5360 Fax: 971-4-886-5361 e-mail: jungyongl@lsis.biz
- **Dalian LS Industrial Systems Co., Ltd.** >> Dalian, China
Address: No.15, Liaohexi 3-Road, Economic and Technical Development zone, Dalian 116600, China
Tel: 86-411-8273-7777 Fax: 86-411-8730-7560 e-mail: lixx@lsis.com.cn
- **LS Industrial Systems (Wuxi) Co., Ltd.** >> Wuxi, China
Address: 102-A, National High & New Tech Industrial Development Area, Wuxi, Jiangsu,214028, P.R.China
Tel: 86-510-8534-6666 Fax: 86-510-522-4078 e-mail: xuhg@lsis.com.cn
- **LS-VINA Industrial Systems Co., Ltd.** >> Hanoi, Vietnam
Address: Nguyen Khe - Dong Anh - Ha Noi - Viet Nam
Tel: 84-4-882-0222 Fax: 84-4-882-0220 e-mail: srjo@lsisvina.com
- **LS-VINA Industrial Systems Co., Ltd.** >> Hochiminh , Vietnam
Address: 41 Nguyen Thi Minh Khai Str. Yoco Bldg 4th Floor, Hochiminh City, Vietnam
Tel: 84-8-3822-7941 Fax: 84-8-3822-7942 e-mail: sbpark@lsisvina.com
- **LS Industrial Systems Tokyo Office** >> Tokyo, Japan
Address: 16FL, Higashi-Kan, Akasaka Twin Tower 17-22, 2-chome, Akasaka, Minato-ku Tokyo 107-8470, Japan
Tel: 81-3-3582-9128 Fax: 81-3-3582-2667 e-mail: jschuna@lsis.biz
- **LS Industrial Systems Shanghai Office** >> Shanghai, China
Address: Room E-G, 12th Floor Huamin Empire Plaza, No.726, West Yan'an Road Shanghai 200050, P.R. China
Tel: 86-21-5237-9977 (609) Fax: 89-21-5237-7191 e-mail: jinhk@lsis.com.cn
- **LS Industrial Systems Beijing Office** >> Beijing, China
Address: B-Tower 17FL,Beijing Global Trade Center B/D. No.36, BeiSanHuanDong-Lu, DongCheng-District, Beijing 100013, P.R. China
Tel: 86-10-5825-6025,7 Fax: 86-10-5825-6026 e-mail: cuixiaorong@lsis.com.cn
- **LS Industrial Systems Guangzhou Office** >> Guangzhou, China
Address: Room 1403,14F,New Poly Tower,2 Zhongshan Liu Road,Guangzhou, P.R. China
Tel: 86-20-8326-6764 Fax: 86-20-8326-6287 e-mail: linsz@lsis.biz
- **LS Industrial Systems Chengdu Office** >> Chengdu, China
Address: 12Floor, Guodong Building, No52 Jindun Road Chengdu, 610041, P.R. China
Tel: 86-28-8612-9151 Fax: 86-28-8612-9236 e-mail: yangcf@lsis.com.cn
- **LS Industrial Systems Qingdao Office** >> Qingdao, China
Address: 7B40,HaiXin Guangchang Shenye Building B, No.9 Shandong Road Qingdao 26600, P.R. China
Tel: 86-532-8501-6568 Fax: 86-532-583-3793 e-mail: lirj@lsis.com.cn

Specifications in this catalog are subject to change without notice due to continuous product development and improvement.